

KANSAS PEACE OFFICERS ASSOCIATION FIREARMS RULES

The following rules and regulations are established to provide an efficient and orderly operation of the annual KPOA Firearms event. The Firearms Committee meets as needed to review the rules and regulations and to resolve any problems that may have developed.

Chairman of Firearms Committee/Event Rangemaster

The Rangemaster has the authority to cancel any part of the shooting events that he considers a safety hazard.

The Rangemaster will make the final decisions on scoring challenges

The Rangemaster will rule on questions regarding firearms, holsters and equipment.

The Rangemaster may disqualify any person violating standard firearms safety rules.

Eligibility to Compete

To compete in the law enforcement division, a competitor must be a commissioned LEO, corrections officer or retired LEO and a current KPOA member.

To compete in the civilian division, competitors must be at least 18 years old and legally eligible to possess a handgun.

Entry Cards

Each individual and team competitor will complete and turn in an entry card during registration for the pistol, shotgun and team events.

Scoring

Scoring will be done by Range Officers using Practiscore

Protest and Challenges

All challenges will be handled by the Rangemaster and two committee members on the range at the time the challenge is made.

Alcohol Beverages

No alcohol beverages will be allowed at the range of any KPOA sponsored firearms event. Violations may result in disqualification of the competitor. Sponsored firearms events include firearms in-service training seminars.

Safety

It is the responsibility of all competitors to observe standard safety rules in handling a firearm during the competition. Firearms will only be handled on the firing line or designated "Safe Areas". Firearms will be unloaded, holstered, carried in a shooting case, or carried with the action open at all times. Those carrying single action semi-automatic pistols will be required, while on the firing line, to carry the weapon with the safety in the on position. Firearms will only be loaded on the command of a Range Officer.

Team Competition

Teams may be formed from 3 competitors from the following divisions:

- Law Enforcement (3 competitors)
- Civilian (3 competitors)

The team registration form must be completed during the match registration.

Team members will compete as individuals, with their final total times of all five (5) pistol events being added together as their team time.

DIVISIONS

There are two divisions in the KPOA Shooting event

- Law Enforcement division

- Civilian division

PISTOL MATCH

The KPOA pistol match consists of five different stages, Speed Plates, Speed Pyramid, Accelerator, Roundabout and Pendulum. These stages not only stress speed and accuracy, but also give the competitors experience in engaging multiple targets at varied sizes and distances.

Law Enforcement competitors will fire the course with a duty weapon of at least 9mm, which is authorized by their department for use while on duty. Civilian competitors will fire the course with a stock unmodified weapon suitable for duty use.

The only modification allowed is the use of different grips that better fit the competitor's hand. The barrel length will not be longer than 6 inches. Only sights that are fixed or adjustable are allowed. All standard safety features of the firearm must operate properly.

No magnum, steel core or armor piercing ammo is allowed

SHOTGUN MATCH

The shotgun match is a single stage event consisting of 17 total targets, 13 steel and 4 clay pigeons. The course is fired from a stationary shooting position with no movement required

Shotguns will be 12 ga pump or semi auto with a barrel length no less than 18" and no greater than 24"

Side saddles and sleeve style shell holders are allowed

The range will provide a Mossberg 930 JM Pro semi auto 12 ga., or competitors can use their own shotgun.

Speed Plates

START POSITION: Standing in shooting box facing targets with firearm in holster. Hands in surrender position above shoulders or hanging straight down at sides. This is the start position for each string of fire

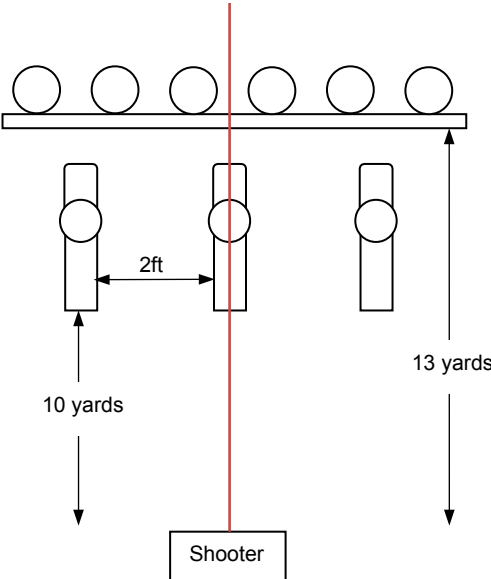
STAGE PROCEDURE	SCORING
<p>3 Strings of Fire</p> <p>At the signal, engage the six plate rack plates and 3 pepper poppers in any order. There will be a mandatory reload per string of fire</p> <p>Firearms and magazines/loaders will be loaded with 6 rounds (12 rounds per string)</p>	<p>Scoring is time plus penalties</p> <p>Plate rack plates must fall to score. Pepper poppers are set not to fall so must only be hit once each to score</p> <p>PENALTIES:</p> <p>Procedural: Add 10 seconds</p> <p>Miss: Add 10 seconds per miss</p>
<p>At the end of the final string of fire, the competitor will unload and show a clear firearm (magazine out, slide locked back, chamber empty, or cylinder open, chambers empty) to the Range Officer, and will then secure the firearm into a holster, bag or box before leaving the firing position and before anyone goes forward to score targets.</p>	
<div style="text-align: center;">  </div> <p style="text-align: right;">1 Bianchi Cup Plate Rack 3 Pepper Poppers</p>	

Speed Pyramid

START POSITION: Standing in shooting box with firearm in holster. Hands in surrender position above shoulders or straight down at sides. This is the start position for each string of fire

STAGE PROCEDURE	SCORING

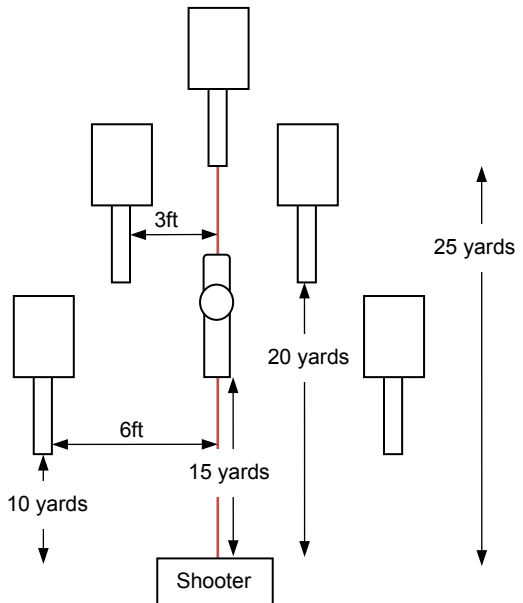
<p>3 Strings of Fire</p> <p>At the signal, engage each steel target with two rounds and the pepper popper with one round in any order.</p> <p>There will be a mandatory reload per string of fire</p> <p>Firearms and magazines/loaders will be loaded with 6 rounds (12 rounds per string)</p>	<p>Scoring is time plus penalties</p> <p>Steel targets must be hit with 2 rounds each</p> <p>Pepper poppers are set not to fall so must only be hit once each to score</p> <p>PENALTIES:</p> <p>Procedural: Add 10 seconds</p> <p>Miss: Add 10 seconds per miss</p>
<p>At the end of the final string of fire, the competitor will unload and show a clear firearm (magazine out, slide locked back, chamber empty, or cylinder open, chambers empty) to the Range Officer, and will then secure the firearm into a holster, bag or box before leaving the firing position and before anyone goes forward to score targets.</p>	
<div style="text-align: center;">  </div> <p style="text-align: right;">5 18x24 Steel Plates 1 Pepper Popper</p>	

Accelerator

START POSITION: Standing in shooting box facing targets with firearm in holster. Hands in surrender position above shoulders or hanging straight down at sides. This is the start position for each string of fire

STAGE PROCEDURE	SCORING
<p>3 Strings of Fire</p> <p>At the signal, engage each steel target with</p>	<p>Scoring is time plus penalties</p> <p>Steel targets must be hit with 2 rounds each</p>

two rounds each in any order.
 There will be a mandatory reload per string of fire
 Firearms and magazines/loaders will be loaded with 6 rounds (12 rounds per string)

PENALTIES:

Procedural: Add 10 seconds
 Miss: Add 10 seconds per miss

At the end of the final string of fire, the competitor will unload and show a clear firearm (magazine out, slide locked back, chamber empty, or cylinder open, chambers empty) to the Range Officer, and will then secure the firearm into a holster, bag or box before leaving the firing position and before anyone goes forward to score targets.

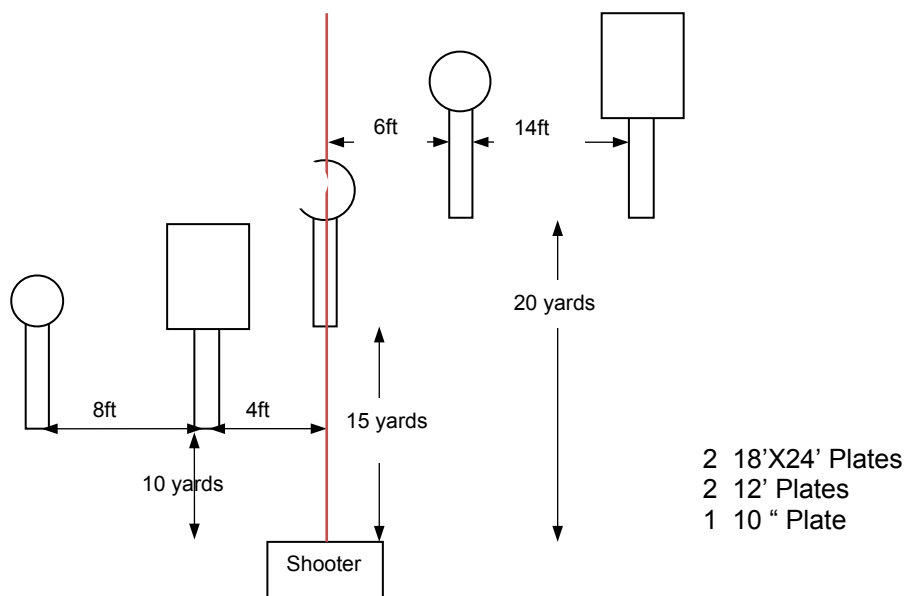

Roundabout

START POSITION: Standing in shooting box facing targets with firearm in holster. Hands in surrender position above shoulders or hanging straight down at sides. This is the start position for each string of fire

STAGE PROCEDURE

3 Strings of Fire

At the signal, engage each steel target with two rounds each in any order.

SCORING

Scoring is time plus penalties

Steel targets must be hit with 2 rounds each

<p>There will be a mandatory reload per string of fire Firearms and magazines/loaders will be loaded with 6 rounds (12 rounds per string)</p>	<p>PENALTIES: Procedural: Add 10 seconds Miss: Add 10 seconds per miss</p>
---	---

At the end of the final string of fire, the competitor will unload and show a clear firearm (magazine out, slide locked back, chamber empty, or cylinder open, chambers empty) to the Range Officer, and will then secure the firearm into a holster, bag or box before leaving the firing position and before anyone goes forward to score targets.

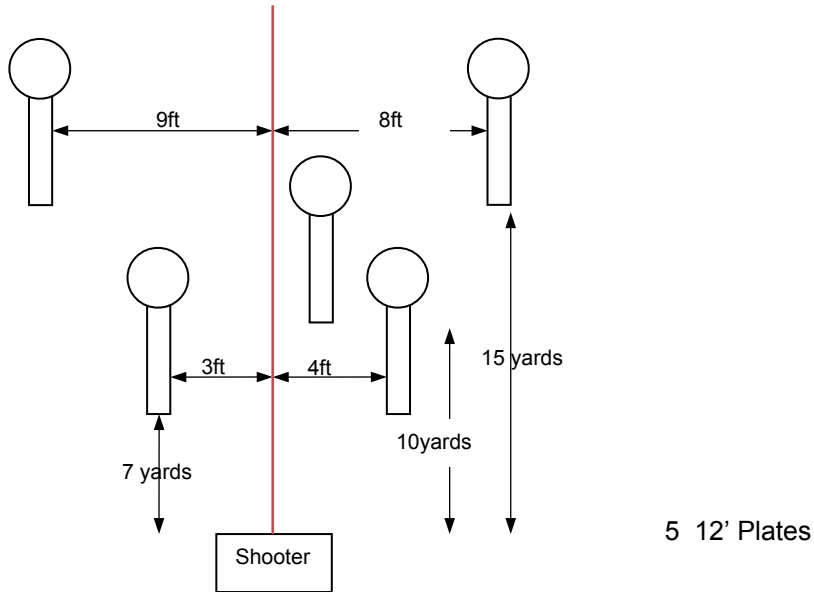

Pendulum

START POSITION: Standing in shooting box facing targets with firearm in holster. Hands in surrender position above shoulders or hanging straight down at sides. This is the start position for each string of fire

<p style="text-align: center;">STAGE PROCEDURE</p> <p>3 Strings of Fire At the signal, engage each steel target with two rounds each in any order. There will be a mandatory reload per string of fire</p>	<p style="text-align: center;">SCORING</p> <p>Scoring is time plus penalties Steel targets must be hit with 2 rounds each</p> <p>PENALTIES: Procedural: Add 10 seconds</p>
--	--

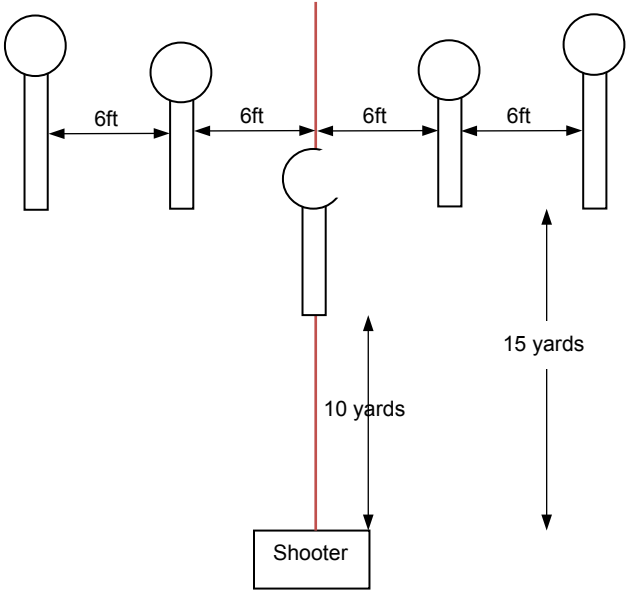
Firearms and magazines/loaders will be loaded with 6 rounds (12 rounds per string)	Miss: Add 10 seconds per miss
<p>At the end of the final string of fire, the competitor will unload and show a clear firearm (magazine out, slide locked back, chamber empty, or cylinder open, chambers empty) to the Range Officer, and will then secure the firearm into a holster, bag or box before leaving the firing position and before anyone goes forward to score targets.</p>	
 <p>5 12' Plates The two end targets are 6" tall All the others are 5" tall</p>	

Shotgun Course

START POSITION: Standing in shooting box with shotgun in low ready, safety on, round in chamber and no more than 8 rounds of birdshot in chamber. Extra rounds loaded from shooter preference

STAGE PROCEDURE

1 String of Fire

At the signal, engage the knock over targets, Texas star, pepper poppers and clay pigeons in any order.

There will be at least 1 reload required to complete the course, depending on the

SCORING

Scoring is time plus penalties

All steel targets must fall to score.

Clay pigeons must be noticeably hit to score

PENALTIES:

Procedural: Add 10 seconds

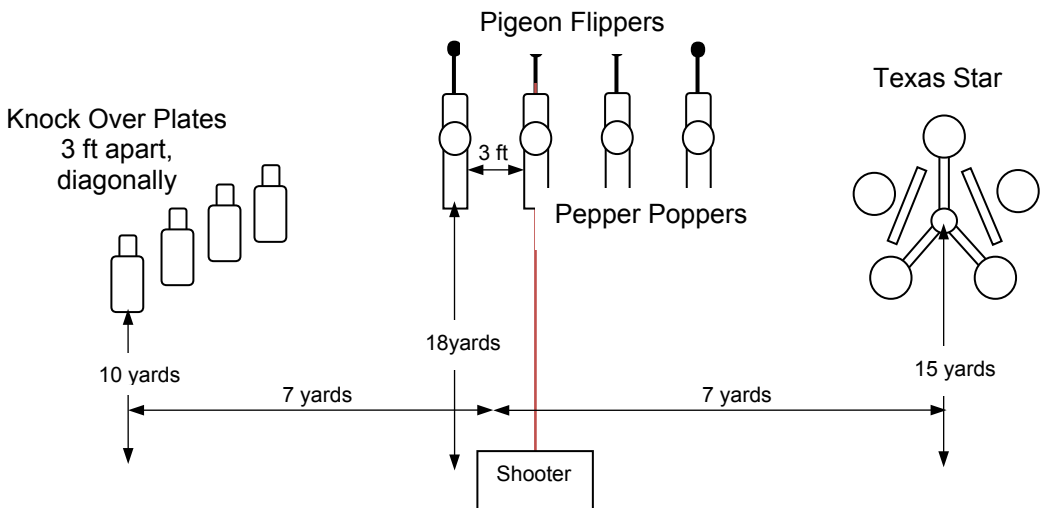
<p>capacity of the shooters shotgun. When the pepper poppers are knocked over the will launch a clay pigeon in the air</p>	<p>Miss: Add 10 seconds per miss</p>
<p>At the end of the course, the competitor will unload and show a clear firearm (action open, safety on) to the Range Officer, and will then secure the shotgun in the rack before anyone goes forward to score and reset targets.</p>	
 <p>The diagram illustrates the layout of a shotgun course. A central 'Shooter' box is positioned 18 yards from a vertical line of four 'Pepper Poppers' targets. To the left, 'Knock Over Plates' are arranged diagonally, 10 yards from the shooter and 7 yards from the poppers. To the right, a 'Texas Star' target is 15 yards from the shooter and 7 yards from the poppers. The poppers are spaced 3 feet apart. 'Pigeon Flippers' are located above the poppers.</p>	

Old Masters Award (Trophy)

The Top Gun winner from the law enforcement and the civilian division will have a shoot off to determine the best overall shooter. The winner of this shoot off will be awarded the Old Masters Trophy. To create an even playing field, the course of fire will be a head to head single stage event set up the day of the event. The competitors will use pistols and ammo provided by the range.

Top Gun Award (Plaque)

This award is given to the competitor in each division with the fastest overall time in all five pistol stages. The winner of this award is not eligible for stage awards.

Individual Stage Awards (plaque for each stage)

These awards are given to the competitor in each division with the fastest time in each of the five pistol stages. Competitors can win only one stage per match. In the event a competitor wins multiple stages, the prize money will default to 2nd, 3rdand so on until there is a different winner in each stage

Prizes will be awarded in the following order:

**Speed Plates, Speed Pyramid, Accelerator
Roundabout, Pendulum**

Novice Award (Trophy)

This award is given to the competitor in each division with the lowest Aggregate Score, who has never competed in KPOA sponsored pistol competition. Competitors have only one chance to win this award.

Shotgun Award (Trophy)

This award is given to the competitor in each division with the fastest overall time in shotgun event.

Team Awards

Team awards are 1st, 2nd and 3rd place plaques for each division. Only one plaque is awarded per team. If you wish additional plaques, please contact our plaque vendor

At the conclusion of the shooting event there will be an awards ceremony held at the range banquet room where the awards will be presented.

Revised Date: 04/19/17